

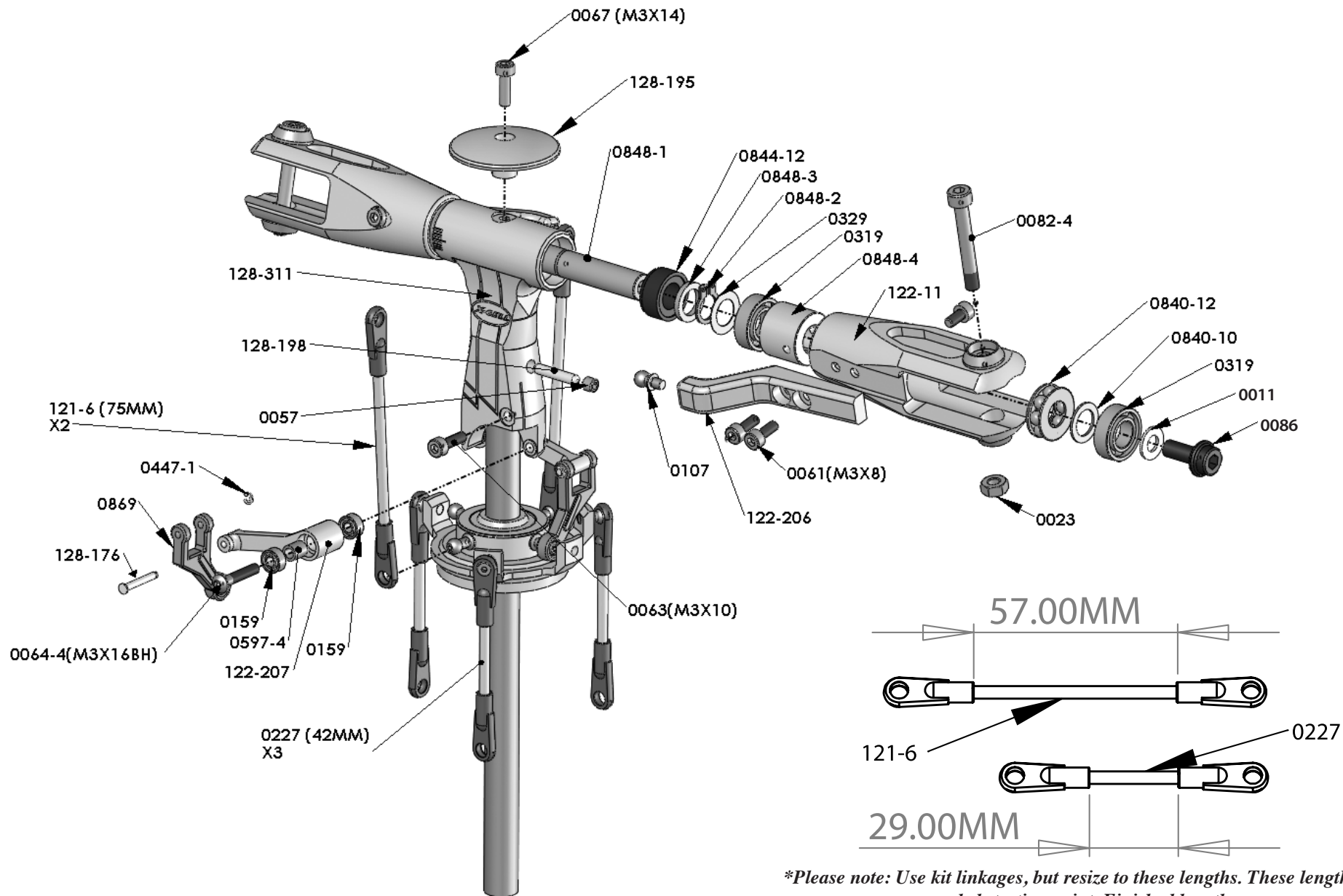

60/90-SIZE FLYBARLESS ROTOR HEAD ASSEMBLY

The MA122-205 Flybarless rotor head designed for X-cell 60/90 size helicopters with 10mm main shaft. For the use of a Flybarless rotor head we HIGHLY recommend the use of electronic stabilization electronics. There are several that are readily available.

Please note that the use of thread locking compound is required for all bolts that are threaded into metal. We recommend using X-Cell super-lock blue (MA3200-22) medium strength.



**Please note: Use kit linkages, but resize to these lengths. These lengths are a recommended starting point. Finished lengths may vary.*